



ModuMAX™ SSPA Systems

C, X, and Ku Bands



Completely modular solid-state power amplifier systems for world-wide satellite communications.

C-Band SSPAs

- 1500 Watts
- 1000 Watts
- 800 Watts

X-Band SSPAs

- 1250 Watts
- 1000 Watts
- 700 Watts

Ku-Band SSPAs

- 500 Watts
- 350 Watts

Phase-Combined Systems

C-Band

- 3000 Watts
- 2000 Watts

X-Band

- 2500 Watts
- 2000 Watts

Ku-Band

- 1000 Watts

A revolutionary concept in solid-state power amplifiers, the ModuMAX series eliminates the need for a spare power amplifier or for redundant switchover networks in many satellite earth station applications.

Protected Under US Patent #6,549,405 B2.

GENERAL DYNAMICS
SATCOM Technologies

System Information

Most satellite earth stations cannot afford down time due to equipment failure, so they employ redundancy—two of everything—at a significant increase in cost and complexity. This made sense when the final amplifier stage was a single tube and thus a single point failure.

However, now that solid state is a viable and practical amplifier technology, solutions other than brute-force redundancy make better sense.

Built-in Redundancy

Since solid-state power amplifiers (SSPAs) consist of multiple transistors in parallel, they naturally contain a degree of built-in redundancy. With proper attention to design architecture, the use of multiple parallel RF modules, and the elimination of all active devices from the common RF path, VertexRSI has designed an SSPA that is reliable and extremely fault-tolerant. With the ModuMAX series, one fault-tolerant SSPA can replace two power amplifiers for a huge savings in installation and operating costs.



Interchangeable RF modules can be hot-swapped for fast and easy servicing.

RF Plug-In Modules

The ModuMAX SSPA consists of eight identical, fully interchangeable RF plug-in modules that are conveniently accessible from the front panel. Module status is visually indicated by an LED on each module as well as the control panel display.

Complete failure of a module causes a drop of only 1.2 dB in output power *without the momentary loss of signal caused by redundant switchover systems*. Defective modules can be hot-swapped while the SSPA continues to operate. Spare RF modules are affordable, since they contain only a fraction of the RF power transistors in the SSPA.

Easy to Operate and Maintain

ModuMAX SSPAs are designed to be easy to operate and maintain. The most commonly used controls are brought out to the front panel for quick and easy access. All features are fully remote controllable through the standard RS-232/-422/-485 and network interfaces. Most servicing can be performed safely while the SSPA continues to operate. Any of the eight fans in the air-cooling system can be easily removed and replaced, all without ever taking the SSPA off-line. Even the power supply is N+1 redundant.



Modular, replaceable components assure ease of maintenance.

Phase-Combined Systems

ModuMAX is easy to expand. Phase-combine two SSPAs for double the power output in only 59.5" (34 RU) of rack space (3 kW C-Band system requires 73.5" [42 RU]). An added bonus—with 16 RF modules, one failed module causes only a 0.6 dB drop in output power.

Global EMC and Safety Compatibility

 ModuMAX SSPA systems are certified to applicable EU EMI/EMC and safety standards.

Cooling System

ModuMAX also incorporates redundancy into its integral forced-air cooling system. Enough margin is built into the design to tolerate the loss of one cooling fan. Fans are monitored for rotational speed, and failure of a fan is indicated on the control panel display. In the event of a fan failure, the SSPA can continue to operate until a replacement is installed. The air cooling system utilizes separate rear panel air intake and exhaust ducts and can be vented either outdoors or into the room.



Modular intake and exhaust fans maintain 400 cfm (0.189 m³/s) volumetric air flow.



The modular power supply is N+1 redundant.

Power

For systems up to 1 kW, system power is supplied by three identical power supply modules in an N+1 redundant configuration; higher output systems require six modules for full redundancy. If a module fails, the remaining ones can supply 100% of the required load current and the defective module can be hot-swapped without interruption. ModuMAX can be connected to 120/208 Vac or 230/400 Vac three-phase sources, or to single-phase 180–264 Vac, allowing considerable flexibility in installations and worldwide operation.

Connector Interface

Ref. Des.	Function	Connector Type	Mating Connector	Comment
RF Unit				
J1	RF Input	Type N Female	Type N Male	
J2	RF Output	CPR137G/CPR112/WR75 Waveguide	CPR137/CPR112/WR75 Flange	C-/X-/Ku-Band
J3	DC In	Bus Bars	Ring Terminals	Supplied
J4	Serial I/O	9-pos D, Female	9-pos D, Male	Supplied
J5	Parallel I/O	37-pos D, Male	37-pos D, Female	Supplied
J7	System Interface	15-pos D, Male	15-pos D, Female	(Future use)
J9	PS Interface	9-pos D, Male	9-pos D, Female	Supplied
J10	RF Input Sample	Type N Female	Type N Male	On front panel
J11	RF Output Sample	Type N Female	Type N Male	On front panel
Power Supply Unit				
+12 V, RTN	DC Output	Bus Bars	Ring Terminals	Supplied
L1, L2, L3, N	AC Input	Terminal Strip	Wires	
J5	PS Status	9-pos D, Male	9-pos D, Female	Supplied
J6	PS Sync	9-pos D, Female	9-pos D, Male	Supplied, if used
J7	PS Sense	9-pos D, Female	9-pos D, Male	Supplied

SIMPLY THE BEST

Outline Drawing

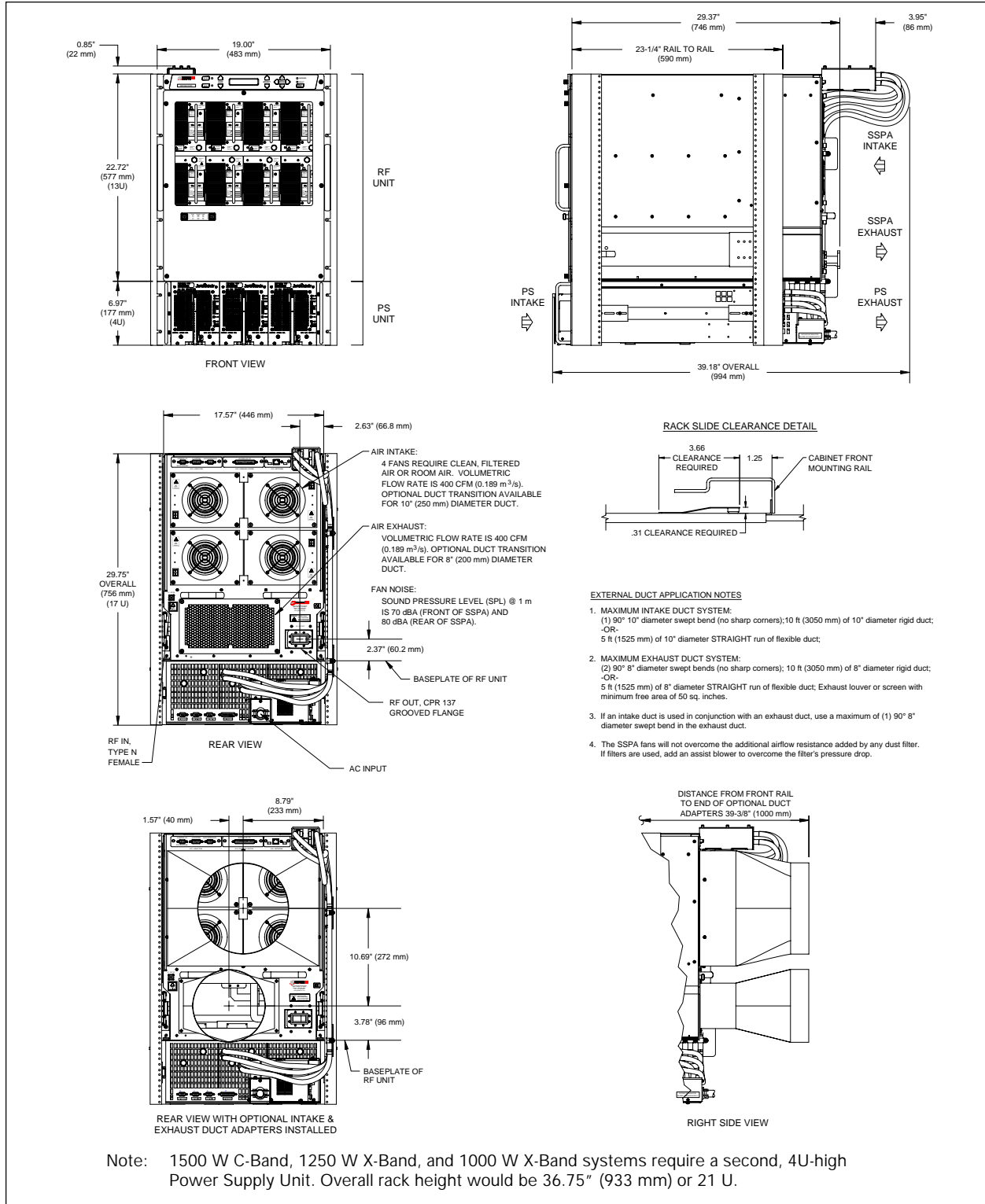

System Block Diagram

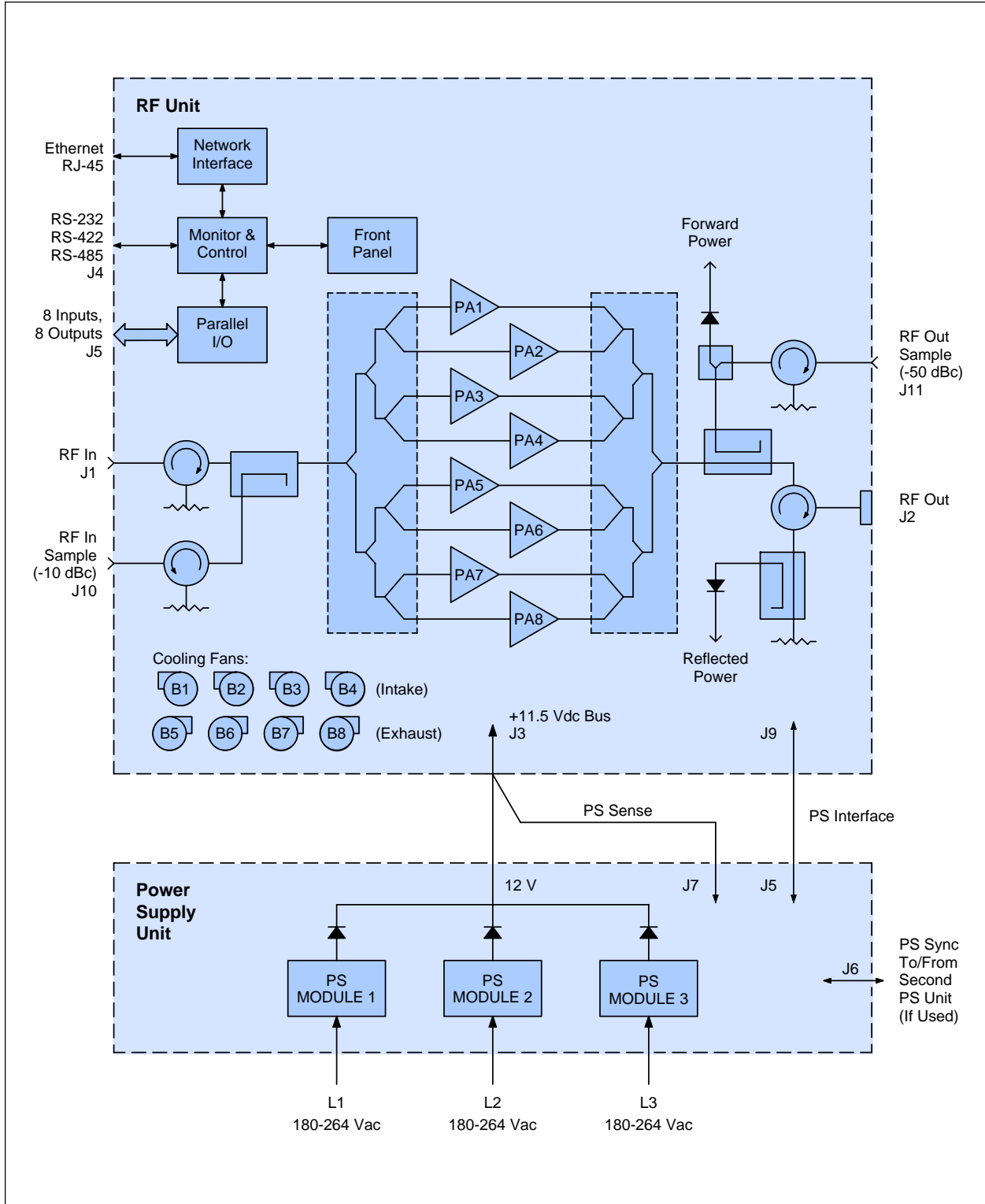

SIMPLY THE BEST

Specifications

Parameter	Conditions	Min	Nom/Typ ⁽¹⁾	Max	Units
Frequency Range ⁽²⁾	C-Band, Standard (MPCD-)	5.850		6.425	GHz
	C-Band, Extended (MPCM-)	5.850		6.725	GHz
	X-Band, Standard (MPXB-)	7.900		8.400	GHz
	Ku-Band, Standard (MPKM-)	14.00		14.50	GHz
	Ku-Band, Extended (MPKO-)	13.75		14.50	GHz
Gain, at Maximum Setting	C-Band	70		75	dB
	X- and Ku-Bands	65		70	dB
Gain vs. Temperature	0 to 50 °C		±0.5	±0.75	dB
Gain Adjust Range	Digital, 0.1 dB steps	20			dB
Gain Flatness	Full band			±1.0	dB
	Per 40 MHz			±0.3	dB
Saturated Power Output	1500 W C-Band		+62.0 (1585)		dBm (W)
	1000 W C-Band		+60.0 (1000)		dBm (W)
	800 W C-Band		+59.0 (800)		dBm (W)
	1250 W X-Band		+61.0 (1250)		dBm (W)
	1000 W X-Band		+60.0 (1000)		dBm (W)
	700 W X-Band		+58.5 (700)		dBm (W)
	500 W Ku-Band		+57.0 (500)		dBm (W)
	350 W Ku-Band		+55.5 (350)		dBm (W)
Power Output, at 1 dB Compression ($P_{1\text{ dB}}$)	1500 W C-Band	+61.3 (1384)			dBm (W)
	1000 W C-Band	+59.5 (900)			dBm (W)
	800 W C-Band	+58.5 (708)			dBm (W)
	1250 W X-Band	+60.3 (1072)			dBm (W)
	1000 W X-Band	+59.5 (900)			dBm (W)
	700 W X-Band	+58.0 (620)			dBm (W)
	500 W Ku-Band	+56.2 (400)			dBm (W)
	350 W Ku-Band	+54.8 (300)			dBm (W)
Two-Tone Intermodulation	At 3 dB backoff from $P_{1\text{ dB}}$		-30	-25	dBc
Residual Noise, C-Band	5.85–6.425 GHz			-70	dBW/4 kHz
	3.4–4.2 GHz			-160	dBW/4 kHz
Residual Noise, Ku-Band	14.0–14.5 GHz			-70	dBW/4 kHz
Group Delay	Linear			0.03	ns/MHz
	Parabolic			0.003	ns/MHz ²
	Ripple			1.0	ns p-p
AM/PM Conversion	At $P_{1\text{ dB}}$		2.5	3.5	°/dB
Second Harmonic	At $P_{1\text{ dB}}$			-60	dBc
Spurious	At $P_{1\text{ dB}}$			-70	dBc
VSWR	Input, Output		1.2	1.3	:1
Sample Ports	Input/Output		-10/-50		dBc
Power Requirements (single or 3-phase)	Voltage	180		264	Vac
	Frequency	47		63	Hz
	Power factor		0.98		
Power Requirements (single or 3-phase)	Power, 1500 W C-Band		7.3	10.5 ⁽⁴⁾	kW
	Power, 1000 W C-Band		6.4	8.3 ⁽⁴⁾	kW
	Power, 800 W C-Band		5.1	5.7 ⁽⁴⁾	kW

For more information ...

For more information about the ModuMAX™ series SSPAs, or to arrange for a demonstration unit, please contact the VertexRSI Sales department in State College, Pennsylvania, at 814-238-2700.

General Dynamics SATCOM Technologies offers a family of satellite and wireless communications products under its VertexRSI, Prodelin, and Gabriel brands. Visit our website at <http://www.gdsatcom.com>.

SIMPLY THE BEST

GENERAL DYNAMICS
SATCOM Technologies

2120 Old Gatesburg Road
State College, PA 16803 USA
Telephone 814-238-2700
Fax 814-238-6589
www.gdsatcom.com